



# OWNER'S MANUAL

## Vectamaxx RSL and RSLHP

### Commercial RO Systems



*Manufactured by:*  
**WATERITE, INC.**

5-200 Discovery Place, Winnipeg, MB, R2R 0P7  
[www.waterite.com](http://www.waterite.com)

# TABLE OF CONTENTS

Frequently Asked Questions.....	3-4
Section 1: Installation .....	5
1.1. Selecting the System Location .....	5
1.2. Feed Water Connection .....	5
1.3. Installing the Pre-Filter Cartridge.....	6
1.4. Installing the Drain Line .....	7
1.5. Product Output Connection .....	7
1.6. Complete the Electrical Connection.....	7
Section 2: System Operation.....	8
2.1. System Controller .....	8
2.2. Controller Programs.....	8
2.3. Switching Between Programs.....	9
2.4. System Startup and Flush Procedure.....	9
2.5. Setting System Operation Pressure .....	10
2.6. Recovery Rates .....	11
Section 3: System Maintenance .....	12
3.1. Pre-Filter Maintenance .....	12
3.2. Pre-Filter Replacement.....	12
3.3. Membrane Service Life.....	12
3.4. Membrane Removal .....	13
3.5. Membrane Installation .....	13
3.7. Monitoring System Performance .....	14
3.8. Auto Flush Feature .....	14
Section 4: Specifications .....	15
System Controller Specifications.....	15
General System Specifications.....	16
Section 5: Troubleshooting .....	17
Section 6: Electrical Information.....	18-19
Section 7: Replacement Parts.....	20-21
Section 8: System Performance Log.....	22
Warranty .....	BACK COVER

---

Dealer Name \_\_\_\_\_ Phone \_\_\_\_\_

Address \_\_\_\_\_ Email \_\_\_\_\_

---

# FREQUENTLY ASKED QUESTIONS

## What factors affect the quality of the water produced?

1. Pressure: The greater the RO system pressure, the greater the water quantity that will be produced by the membrane.
  - a. The VectaMaxx™ RSL units have been equipped with ultra-low energy membrane(s) that are designed to operate at a minimum system pressure of 100 psi and a maximum of 135 psi for 2400 and 4800 models, 140 psi for 7200 and 9600 models. Do not attempt to operate your RSL system at pressures exceeding 150 psi, as damage to the membrane or premature fouling may result.
  - b. The VectaMaxx RSLHP units have been equipped with brackish water membranes that are rated for 225 psi. All RSLHP units are designed to operate to a maximum pressure of 250 psi.
2. Temperature: Production increases with temperature, standard production ratings are established at 77°F (25°C). Never operate the system from the hot water line or with water exceeding 95°F (35°C), as this will damage the membrane and internal components.
3. Membrane type: VectaMaxx™ RSL systems use premium quality TFC (Thin Film Composite) membranes, specially chosen for general commercial applications. Please contact your dealer for information on special applications or nanofiltration membranes.
4. TDS: Higher TDS (Total Dissolved Solids) in the raw water lowers the output and quality of product water.

## How much water will my system produce?

The VectaMaxx™ RSL systems use membranes each nominally rated for 2400 gallons per day (GPD). Actual output will be dependent upon the factors noted previously. In optimal applications (low feed water TDS, feed water of 77°F or 25°C), you may expect up to 1600-2200 GPD from each membrane over a 24-hour period.

The VectaMaxx™ RSLHP units use membranes each nominally rated for 2000 GPD. Actual output will be dependent upon the factors noted previously. In optimal applications, feed water at 77°F (25°C), you may expect 1300-1800 USG from each membrane over a 24-hour period. Consult your water treatment professional for a production estimate based on your specific water conditions.

If your system is equipped with the Pretreat Lockout option, no production will be available during the Pretreat regeneration cycle. This will prevent the system from operating periodically with untreated feed water and prolong the life of the filter and membranes.

## How can I get more water?

The overall quantity of water available for consumption over a 24-hour period can be improved by increasing storage capacity. This will allow the system to produce water in off-peak hours instead of sitting idle. This will also increase storage capacity available during peak hours when water usage may exceed production capacity.

## What is the maintenance schedule for the system?

The pre-filter should be changed monthly in most commercial applications. Consider changing them biweekly when in continuous use or when used with untreated water sources. Depending on feed water quality, your membrane(s) should have a life expectancy of 1-3 years. More severe water conditions (iron, hardness) may shorten this significantly; soft water sources may allow a membrane life of up to 5 years.

## Do membranes wear out?

As your membrane ages, it will gradually lose some output. This is normal and may result in a production loss of 5% after about 1 year. Your membrane(s) may eventually begin to lose production due to fouling or scaling in its interior. Symptoms of this may be continuously falling production rates or elevated TDS levels in the product water. Do not attempt to operate the system above specified pressures to compensate for output loss. Membrane element life will range from 1 to 3 years, depending on the quality of the feed water. See: [Section 3: System Maintenance](#) for membrane removal and installation instructions.

**It is a good idea to always keep an extra membrane(s) on hand to avoid system downtime. Never allow a membrane to dry out (if wet variety) or freeze while in storage.**

## When should the membrane(s) be changed?

If you notice gradually decreasing production from your system, differing taste to your drinking water or a rising Total Dissolved Solids reading, it means that your membrane(s) are deteriorating and losing effectiveness. The TDS meter on the unit will measure the TDS of feed water and the product water.

Where the RO system is used as a pre-treatment for a process requiring water to exact standards, you should adopt a regular ongoing sampling and testing procedure to ensure compliance, as product water will vary with the quality of the feed water.

## Can I use a pressurized storage tank with my system?

Yes, your system can be connected to a pressurized storage tank for certain applications. Please contact your dealer for more information about pressurized storage tank applications. They will provide you with the specific information necessary for this type of application.

## Should I be using a storage tank and float switch?

Your VectaMaxx™ RSL system may be wired to a float control shut-off switch that shuts the system off when a non-pressurized storage tank is filled. Size the tank to provide adequate water storage for your peak demand period. Keep in mind that atmospheric water storage vessels are subject to contamination by airborne bacteria – they should include a lid, be sanitized before use, and periodically disinfected. RO product water will have no residual chlorine and will be subject to contamination at all stages in the plumbing system. Consider UV disinfection as an inline option for all water being pumped from the storage tank into the plumbing system.

An overflow bulkhead with a drain line should be installed in the tank above the float switch water line and be connected to a floor drain to protect against a failed level control switch. If the inlet bulkhead fitting to the non-pressurized tank is below the maximum water level in the tank, make sure that a check valve is installed in the product water line between the RO unit's outlet and the tank inlet. This will ensure that backpressure from the tank will not damage the membrane(s). To eliminate this problem, install the bulkhead fitting above the floatswitch. Float switch contacts should be closed when the tank is empty, and open when the tank is full.

Consult your **Waterite commercial RO systems dealer** for information and availability on a wide variety of water system components including storage tanks, re-pressurization pumps, bulkheads, tube, pipe, pressure switches, fittings, UV disinfection systems and float valves.

!

**TEST THAT THE PRE-TREATMENT SYSTEM IS DELIVERING RO FEED WATER TO NECESSARY SPECIFICATIONS BEFORE PLUMBING THE RO SYSTEM ONLINE.**

!

**ALWAYS ALLOW A NEW SOFTENER INSTALLED TO PRE-TREAT AN RO SYSTEM TO START ON THE BACKWASH/ REGENERATION/RINSE CYCLE. OPERATE THE SOFTENER OFF-LINE UNTIL WATER RUNS CLEAR BEFORE USING IT TO PROVIDE RO FEED WATER. THIS PROCEDURE ALSO APPLIES TO NEW RESIN BED INSTALLATIONS. COLOUR THROW FROM NEW RESIN BEDS MAY DAMAGE OR FOUL RO MEMBRANES.**

!

**WATERITE DOES NOT RECOMMEND THE USE OF A GRANULAR CARBON CARTRIDGE IN THE PRE-TREATMENT FILTER HOUSINGS SUPPLIED, FOR THE PRIMARY REDUCTION OF CHLORINE. IT WILL REQUIRE REPLACEMENT TOO OFTEN, LIMIT FLOW RATES AND LIKELY LEAD TO CHLORINE BREAKTHROUGH TO THE MEMBRANE ELEMENT. WE RECOMMEND THAT THIS HOUSING BE RESERVED FOR 5-MICRON OR 1-MICRON SEDIMENT CARTRIDGES, FOR THE REDUCTION OF SUSPENDED PARTICULATE.**

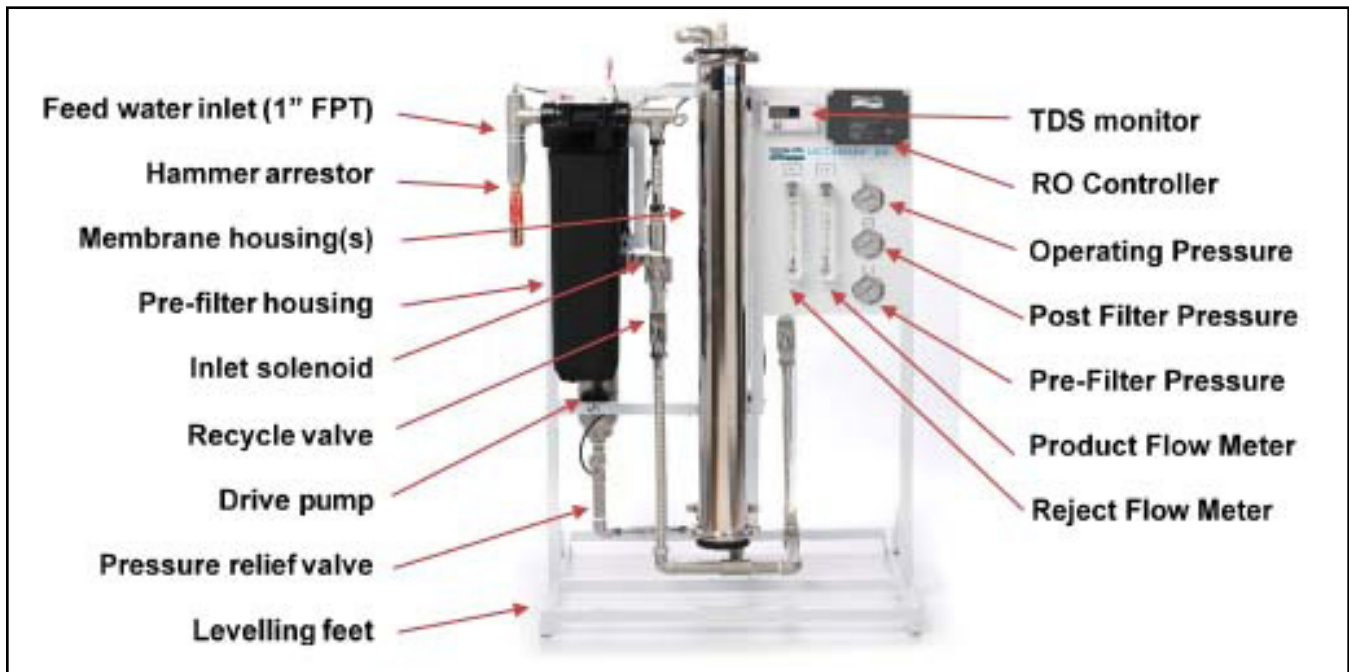

Figure 1

# SECTION 1: INSTALLATION

Your system includes:

- The main RO/filter assembly frame with one assembled pre-filter, booster pump, membrane housing(s), flow controls, pressure gauges, flow meters and TDS meter.
- One, two, three or four pre-installed membrane(s) and one 5-micron polypropylene sediment cartridge
- One sediment filter housing wrench
- One Owner's package including owner's manual and warranty certificate.

Locate your unit's model and serial numbers, as well as voltage on the back of the gauge panel, behind the controller. You can enter this information on the form on page 22 for quick reference.

See: [Section 6](#) for electrical requirements for auxiliary input connections to the RO controller.

Your RO system has been equipped with quality threaded and push-on fittings throughout. All compression fittings should be hand-tightened and then tightened ¼ turn further with a wrench. Check that all fittings are snug, as they may have loosened in transit. Do not over-tighten as damage may occur to the internal gasket on the threaded hose assemblies.

<b>COMMERCIAL REVERSE OSMOSIS SYSTEM</b> <b>SYSTÈME DE FILTRATION PAR OSMOSE INVERSEE COMMERCIALE</b>	
<b>VECTAMAXX™ RSL</b> <input type="text"/>	
Manufactured by / <i>Fabriqué par:</i> Waterite, Inc., Winnipeg, MB, Canada <b>FOR INDOOR USE ONLY - UNIQUEMENT POUR UTILISATION INTERIEURE</b>	
	Input / Entrée: 230Vac 60Hz <input type="text"/> A
	Working Pressure / Pression: <input type="text"/> psig
	Serial / N. de Série: <b>000000</b>
	Date of Manufacture: <input type="text"/>
Conforms to / Conforme à ANSI/UL Std. 979 Certified to / Certifié à CAN/CSA Std. C22.2 No.68	

Completing and securing a push-on connection is simple. First, the tubing should be cut square and any burrs or rough edges removed. Insert the tube firmly and push until the tube end contacts the stop. Gently tug the tube backwards to assure a secure connection. To disconnect, pull the tube while pushing in the collet ring. Fittings may be disconnected and re-connected, if necessary.

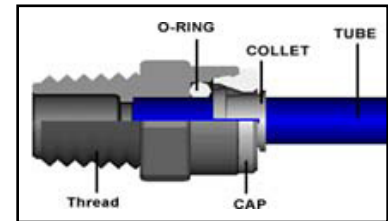

**Figure 2**

## 1.1. Selecting the System Location

1. The filter housing will need periodic maintenance - easy access must be maintained. Do not install in a location with high humidity, direct sunlight or a direct source of heat. Typically, a commercial mechanical room is ideal. Never expose the RO unit to freezing temperatures or direct sunlight.
2. The unit will need to be installed in a location that has access to 230/208VAC power, a feed water line, a drain capable of handling the waste flow from the machine and close to the storage tank.
3. Make sure the feed water source is capable of constant feed water delivery between 40 psi and 60 psi maximum. Your RO system has been equipped with an emergency low pressure shut-off. If the line pressure to your RO inlet falls below 20 psi, this will keep the drive pump from running dry and damage occurring to its internal components.

## 1.2. Feed Water Connection

1. Inspect the feed water supply line and the condition of the pipe. Ensure that the supply pipe is in good overall condition and can deliver the system's necessary feed water flow rate. See: [Section 4](#) or specified feed water flow rate requirements. **Do not use hot water as feed water.**
2. Turn the water supply line to your plumbing **OFF**.
3. Position the unit as necessary and use the threaded feet at the base of the RO stand to level the unit. Remember to leave access to the filter and membranes for maintenance.
4. Install the hammer arrestor assembly into the port on the filter housing.
5. Connect black ¼" poly line from pressure gauge to the fitting on hammer arrestor assembly.
6. Connect the water supply line, ensuring that the feed line is at least ¾" in diameter (1" for RSL 9600 and RSLHP9600). Note: The inlet connection to your RO system is 1" FNPT. A pipe union in the feed water supply line to allow easy disconnection is recommended. (Figure 3).
7. Install a shut off valve on the connection, so that the RO system can be isolated from the main water supply during maintenance.



**Figure 3**

### 1.3. Installing the Pre-Filter Cartridge

**Rubber/Nitrile Gloves must be used to prevent microbial contamination.**

Skip to step 1.4. if the factory has pre-loaded your filter elements.

1. Remove the filter housing by turning counterclockwise with the housing wrench supplied (Figure 4).
2. Inspect O-ring for damage and to make sure it is seated correctly (Figure 5).
3. Remove plastic wrap from the filter cartridge. Insert filter into housing and reassemble. – **DO NOT OVERTIGHTEN** – 1/4 turn after hand tight is usually sufficient. See Section 8 for replacement cartridge part number.



**Figure 4**



**Figure 6**



## 1.4. Installing the Drain Line

1. A 1/2" poly tube (minimum) should be used for the hard plumbed drain line.
2. Attach the drain line to the 1/2" fitting on top of the flush solenoid (Figure 6).
3. Position the drain line over the drain and secure leaving a 2-3" air gap. Do not elevate the drain line over 10 feet above the unit.
4. If connection to a sewer line is necessary, check the local code or a plumbing professional for guidance and the required parts. Drain line should be 3/4".

!

**ALWAYS MAINTAIN OR INSTALL A 2" AIR GAP ON ALL DRAIN LINES TO PREVENT SEWAGE BACK SIPHONAGE.**



**Figure 7**

**DO NOT** use a residential septic field for receiving the RO waste from VectaMaxx™ RSL systems. If used to capacity, these systems (depending on the model and settings) will produce between 1670 to 9820 USG (6,300 to 37,400 litres) per day of wastewater and will waterlog septic beds.

## 1.5. Product Output Connection

1. The port at the top of the product flow meter is where the system will connect to the plumbing system for distribution of product water.
2. The flow meter connection is equipped with 1/2" NPT threads, and a 1/2" push-on fitting.
3. Connect the top port of the product flow meter to the distribution system. Be sure to include a check valve to prevent back flow from the distribution system. **If a check valve is not present, the distribution system can back feed the system and leak to drain, damaging membrane. (Figure 3)**

## 1.6. Complete the Electrical Connection

1. Connect 12 ga minimum, 3 wire cable from the control box to an approved electrical breaker or a disconnect switch as per local electrical code.
2. Connect cable to supply power terminal block in the Control Box as per electrical codes.
3. Connect Tank Float, or Pressure switch to appropriate terminal (if applicable). See Section 6. Float switch contacts should be closed when the tank is empty, and open when the tank is full. Please refer to the instructions provided with the float switch for more detail. Note: Switch connections are **Dry Contact / Voltage Free** only.

**NOTE:** Local electrical codes vary. Check with an electrician for appropriate device connection in accordance with local codes. Assure the power source is rated to the necessary current (see below) and that connections meet the local electrical code. See Section 6 for electrical diagram.

	230/208VAC 1 PH		230/208VAC 1 PH
<b>RSL2400</b>	8.7/9.4 A	<b>RSLHP2400</b>	15.0/16.5 A
<b>RSL4800</b>	8.7/9.4 A	<b>RSLHP4800</b>	15.0/16.5 A
<b>RSL7200</b>	10.4/11.5 A	<b>RSLHP7200</b>	15.0/16.5 A
<b>RSL9600</b>	10.4/11.5 A	<b>RSLHP9600</b>	15.0/16.5 A

Consult an electrician if supply power is subject to variability. A boost transformer may be necessary especially in rural areas with 208V supply. Other motor voltages are available as a factory option. Consult your dealer for availability and pricing.

!

**DO NOT START THE SYSTEM UNTIL STEPS 2.4-2.5 ARE COMPLETED.**

# SECTION 2: SYSTEM OPERATION

## 2.1. System Controller

### Standby/ON Switch

Capacitive touch switch. Tank Full LED turns Red to confirm button contact. To switch to states, hold for 1-2 seconds.

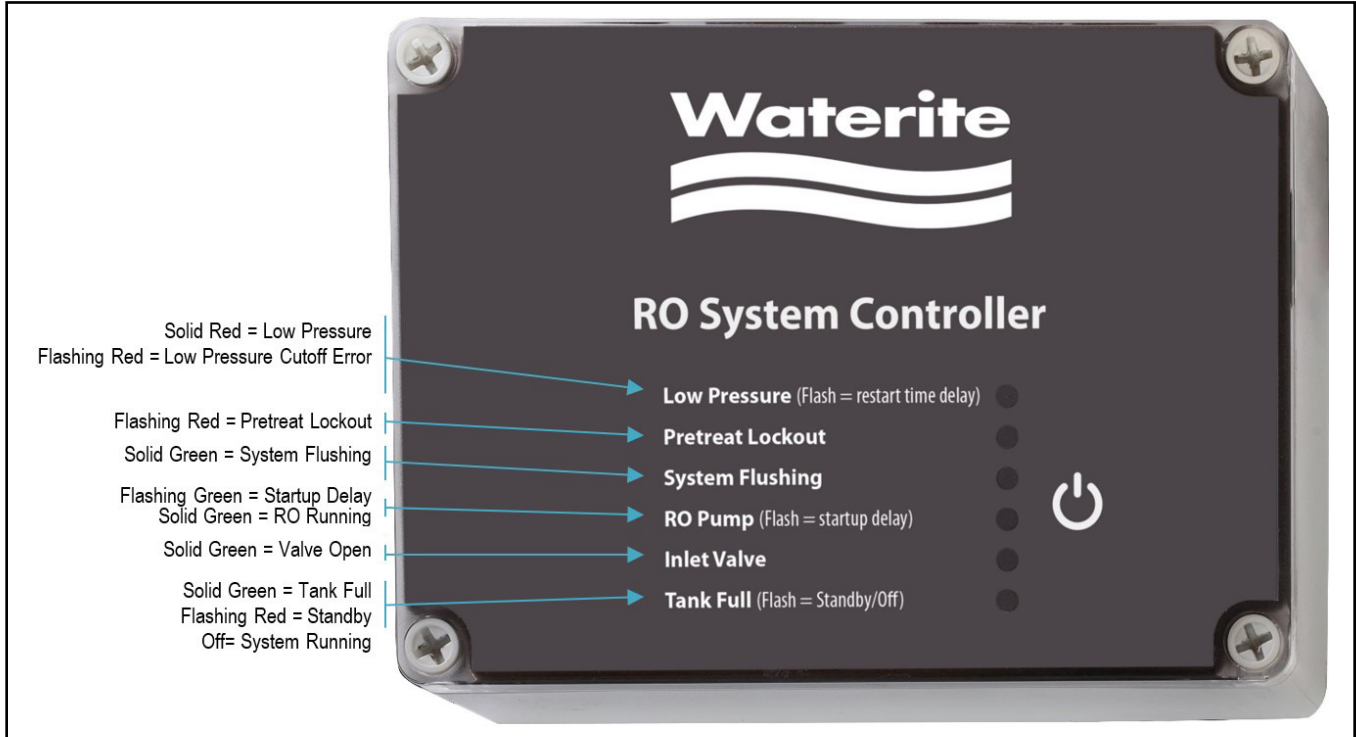

Figure 7

### Manual Mode

Press and hold ON switch for 3-5 seconds will activate manual mode. Unit will run for 5 minutes then turn off.

## 2.2. Controller Programs

The controller has 2 separate user-selectable settings for configuring the RO. The settings are identical except for variations in the membrane flush procedure. If your feed water is a municipal water supply use program 1 as you are starting with clean and treated water. If your feedwater has high TDS, Program 2 is recommended as it will increase membrane life. It will also increase water consumption.

**Program 1, No Flush (Default, Preset at factory)**

**Program 2, Auto Flush (Option)**

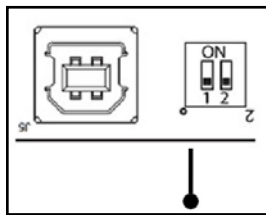

### RO Program Settings

Switch 1	Switch 2	Program
ON	OFF	1
OFF	ON	2

Figure 8



## 2.3. Switching Between Programs

1. Changing between the 2 programs is done by setting the DIP switch positions as shown in Figure 8.
2. Disconnect power or turn off breaker.
3. Remove control cover.
4. Locate DIP switches near bottom of circuit board.
5. Position switches for desired program (Figure 8)
6. Close cover.
7. Reconnect power.

Parameter	Units	Program 1	Program 2
Tank Level Switch delay	Seconds	2	2
Pressure Switch delay	Seconds	2	2
Pretreat Switch delay	Seconds	2	2

Pump start delay	Seconds	10	10
Inlet Solenoid stop delay	Seconds	1	1
Pump start retry interval (restart delay after LP fault)	Seconds	60	60

Low pressure fault shutdown	Attempts	5	5
Low pressure fault shutdown, time count	Minutes	10	10
Low pressure fault shutdown, reset after shutdown	Minutes	60	60
Low pressure timeout fault	Seconds	60	60

Flush Behavior		No Flush	High Pressure
<b>Startup Flush:</b> Minutes from last flush	Minutes	0	0
<b>Startup Flush:</b> Duration	Seconds	0	0
<b>Periodic Flush:</b> Interval	Minutes	0	60
<b>Periodic Flush:</b> Duration	Seconds	0	60
<b>Shutdown Flush:</b> Time from last flush	Minutes	0	10
<b>Shutdown Flush:</b> Minimum operation	Minutes	0	30
<b>Shutdown Flush:</b> Duration	Seconds	0	60

Timed Manual Run	Minutes	5	5
Timed Manual Flush	Minutes	0	5

## 2.4. System Startup and Flush Procedure

1. Turn on the feed water valve to the system.
2. Check all connections for leaks. Do not proceed until leaks are fixed. pre-filter pressure should now be visible on gauge.
3. Purge air from the filter housing by depressing the red purge button (Figure 4) until water comes out. (Tip: place towel over purge button to catch escaping water)
4. Open the recycle valve to the fully open position.
5. Fully open the concentrate reject valve.
6. Turn on breaker/disconnect switch.
7. Press the ON button for 2 sec.
8. Once the pump is running and all air is purged from the system, close the Reject valve (Figure 10) until you have a flow rate of 5 GPM. Let the system operate for about 5 minutes with Recycle valve fully open.
9. The system is now flushing preservative from the membrane. There will be minimal production from the machine during this time.

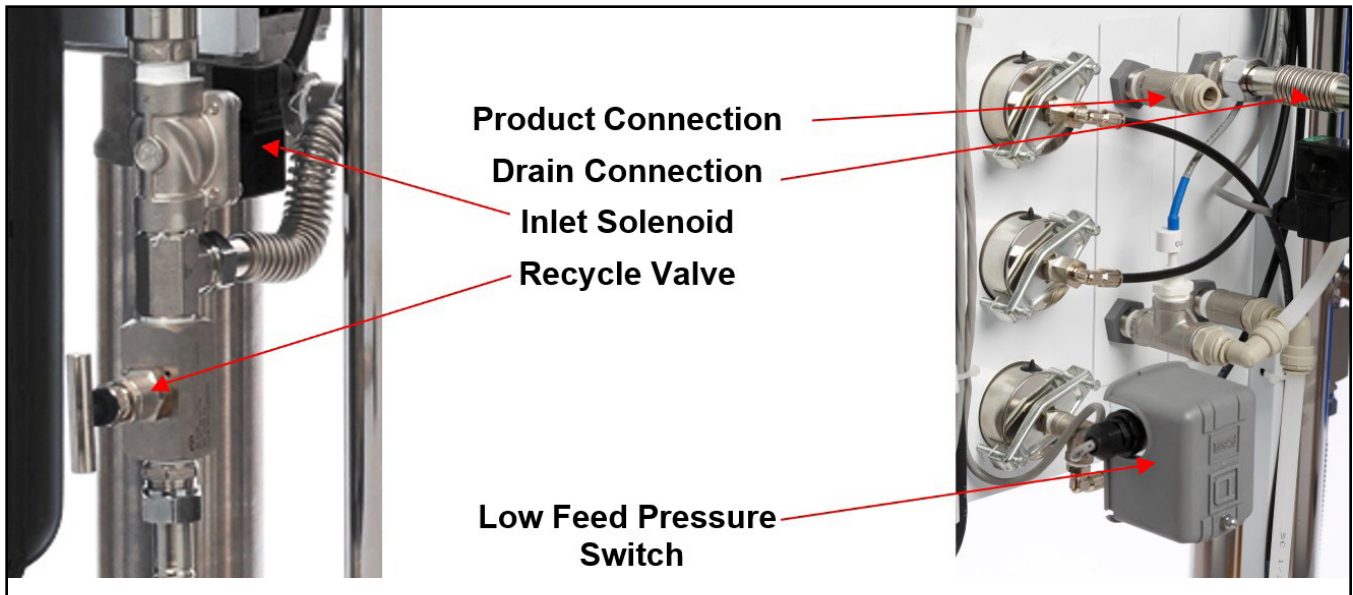

Figure 9

## 2.5. Setting System Operation Pressure

### RSL Units:

1. Slowly close the Reject valve (Figure 10) until the Reject Flow Meter is about 3 GPM.
2. Slowly close the Recycle valve (Figure 11) until system pressure is 130 PSI for 2400 and 4800 models or 140 PSI for 7200 and 9600 models.
3. Adjust both valves until the pressure is stabilized as noted above and a 2:3 ratio of Reject flow to Product flow is achieved.
4. RSL systems are designed to operate normally at 130 PSI for 2400 and 4800 models and 140 PSI for 7200 and 9600 models. **DO NOT ALLOW THE SYSTEM TO OPERATE IN EXCESS OF 150 PSI AS MEMBRANE AND SYSTEM DAMAGE MAY RESULT.** You may wish to lock the valves in the proper position by removing the handles to discourage tampering.
5. Your system is now set up to operate at its designed settings.



Figure 10

### RSLHP Units:

1. Slowly close the reject valve (Figure 10) until the reject flow is about 3 GPM.
2. Slowly close the recycle valve (Figure 11) until the pressure is 210 PSI.
3. Adjust both valves until the pressure is stabilized at 220 PSI with a 2:3 ratio of reject flow to product flow.
4. The RSLHP systems are designed to normally operate at 220 PSI. At this pressure, the proper waste/production ratio is established. **DO NOT ALLOW THE SYSTEM TO OPERATE IN EXCESS OF 250 PSI AS MEMBRANE AND SYSTEM DAMAGE MAY RESULT.** You may wish to lock the valves in the proper position by removing the handles to discourage tampering.
5. Your system is now set up to operate at its designed settings.



Figure 11

!

**MEMBRANES ARE SHIPPED WITH AN ANTI-BACTERIAL PRESERVATIVE. OPERATE THE SYSTEM FOR 1 HOUR TO ASSURE MEMBRANE HAS BEEN COMPLETELY FLUSHED. DO NOT USE WATER PRODUCED DURING THIS RUN-IN PERIOD.**

## 2.6. Recovery Rates

Your VectaMaxx™ RSL is designed to operate at a recovery rate (percentage of product water to total water used) at maximum of 60% for feed water of <1000 TDS and 40% for feed water with TDS ranging from 1000 to 2000.

You may wish to operate your system at lower recovery rates where your dealer has identified water conditions that may stress your membrane or where recommended pre-treatment feed water conditions are not met. You may do so, though this must be accomplished by a combination of increasing the flow of concentrate to waste and reducing the recycle valve flow. This, done in balance, will maintain the overall system pressure at previously stated normal operating pressures. Adjust the reject valve to set the flow rate using the flow meters and close the recycle valve until the pressure registers normal operating pressure. Compare flow rates using the formula:

$$\% \text{ Recovery Rate} = \frac{\text{Flow rate of Permeate (Product Flow)}}{\text{Permeate Flow rate} + \text{Waste Flow rate}}$$

Once the new balance has been established at normal operating pressure, you may wish to lock the valve in position by removing the handles. This can be done by loosening the setscrews located in the valve handle.

!

**DO NOT ATTEMPT TO OPERATE THE SYSTEM AT HIGHER RECOVERY RATES, AS THIS WILL CAUSE PREMATURE MEMBRANE FAILURE OR INTERNAL SCALING AND EQUIPMENT FAILURE.**

# SECTION 3: SYSTEM MAINTENANCE

## 3.1. Pre-Filter Maintenance

Feed water quality will affect the pre-filter service life. A pressure differential between the pre-filter pressure and post-filter pressure gauges greater than 10 PSI indicates the need to replace the filter. This is critical to ensure the pre-treatment filter will allow the necessary flow and that suspended particulate is removed from the feed water. This will increase membrane lifespan and improve production.

## 3.2. Pre-Filter Replacement

**Rubber/Nitrile gloves must be used to prevent microbial contamination.**

1. Turn off the system's power as a safety precaution.
2. Shut off the water supply to the unit.
3. Depressurize system by pressing red purge button (Figure 3)
4. Remove the filter housing by turning counterclockwise with the housing wrench supplied. (Figure 3)
5. Remove used filter from housing. Inspect inside of housing for sediment / scale. Clean and rinse.
6. Dry thoroughly with clean, lint free cloth or compressed air.
7. Inspect O-ring for damage and verify it is seated correctly. (Figure 4)
8. Remove all plastic wrapping from filter cartridge. Insert the new filter in the housing and reassemble. – **DO NOT OVERTIGHTEN** – 1/4 turn after hand tight using the supplied filter wrench is usually sufficient. Always use Waterite factory replacement cartridges.
9. Turn on water supply.
10. Purge the air from the filter housing by depressing the red purge button until water comes out. (Tip: place towel over purge button to catch escaping water) (Figure 3)
11. Wipe area dry and inspect for leaks. If water is leaking from filter housing seal, repeat steps 2-9.
12. Turn on power.

## 3.3. Membrane Service Life

If you notice a decrease in production from your system, different taste to your drinking water or an increase in Product TDS, this signifies that your membrane(s) are deteriorating and losing effectiveness. On units with multiple membranes, replace them at the same time. Where the RO unit is used for pre-treatment requiring water to exact standards, regular ongoing sampling and testing procedures are necessary to ensure compliance.

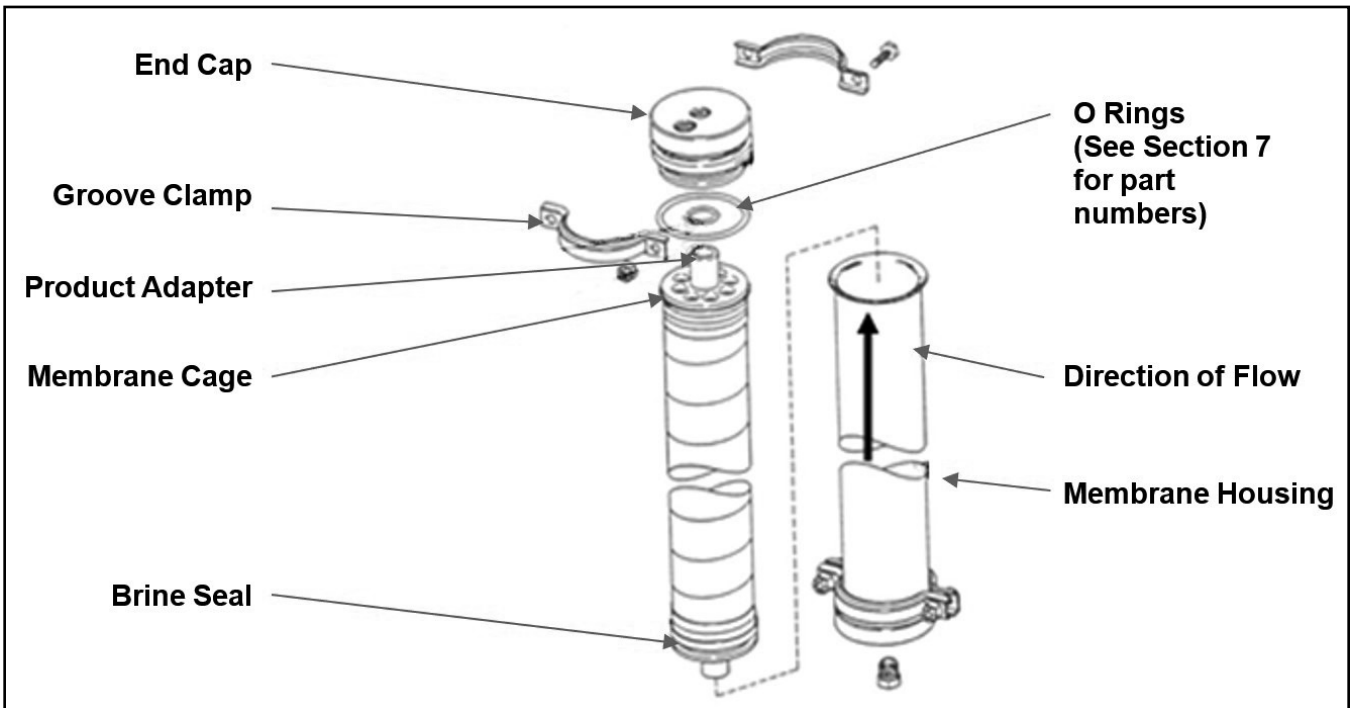

Figure 12

### 3.4. Membrane Removal

Rubber/Nitrile gloves must be used to prevent microbial contamination.

1. Turn off the system's power as a safety precaution.
2. Shut off the water supply to the unit.
3. Verify operating pressure gauge is reading 0 PSI.
4. Loosen bolts and slide top end cap clamp down housing out of the way. (Figure 13)
5. Repeat on all remaining membrane housings.
6. Firmly grasp housing end cap(s) and using a rocking motion, remove them from the housing(s).
7. Lay the housing end cap assembly to the side and remove membrane by lifting it from the housing. Pliers may be necessary to grasp the membrane if it has been installed for an extended period. (Figure 14)



Figure 13



Figure 14

### 3.5. Membrane Installation

Rubber/Nitrile gloves must be used to prevent microbial contamination.  
Note the Direction of flow label on membrane housing(s).

#### Down Flow Membranes

1. Remove plastic wrapping/package from the membrane element(s).
2. Lightly lubricate the membrane brine seal and all O-rings located in the membrane housing caps with a good quality, silicone O-ring lubricant (**DO NOT** use petroleum-based lubricants).

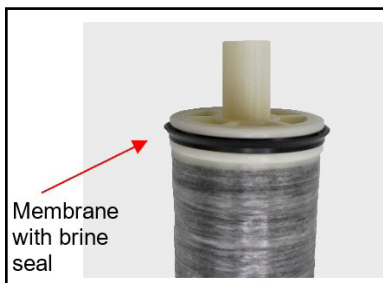

Figure 15



Figure 16

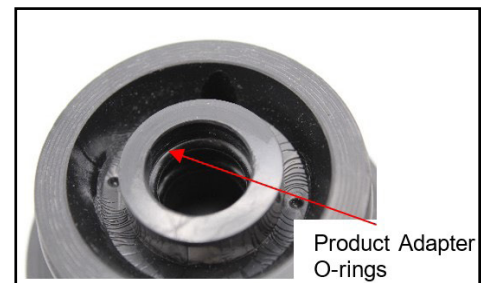
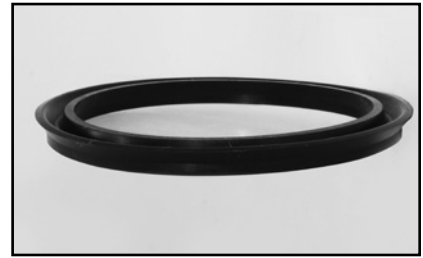

Figure 17

3. Insert the membrane element into the housing, so that the brine seal of the membrane will seat at the inlet side of the membrane housing (this is indicated by the direction of flow label on the housing).
4. Gently push and slowly twist the membrane until the product adapter fully seats inside the housing cap still in place at the bottom of the housing.
5. Repeat steps 8-10 for remaining membranes.
6. Inspect housing end cap O-rings for damage and to make sure they are seated correctly. Figure 16 & 17
7. Re-install the housing end cap assembly into housings using rocking motion.
8. Re-install the band clamp and snug bolts equally to maintain an even gap between the clamp halves.
9. Repeat steps 6-8 on any remaining housing end cap assemblies.

## Up Flow Membranes

1. Loosen bolts on bottom end cap clamp and slide the clamp down out of the way.
2. Firmly grasp housing end cap(s) and using a rocking motion, remove them from the housing(s)
3. Remove plastic wrapping/packaging from the membrane element(s).
4. Remove membrane brine seal from membrane. (Figure 18)
5. Insert membrane into housing allowing brine seal end to extend below housing.
6. Re install brine seal noting orientation direction on flow label. Lightly lubricate the membrane brine seal and all O-rings located in the membrane housing caps with a good quality, silicone O-ring lubricant (**DO NOT** use petroleum-based lubricants).
7. Re-install the lower end cap assembly into housings using rocking motion.
8. Re-install the lower band clamp and snug bolts equally to maintain an even gap between the clamp halves.
9. Ensure the membrane product adapter is fully seated inside the housing cap at the bottom of the housing.
10. Repeat steps 10-18 for remaining membranes.
11. Re-install the top housing end cap assembly into housing(s) using rocking motion.
12. Re-install the band clamp and snug bolts equally to maintain an even gap between the clamp halves.
13. Repeat steps 20-21 on any remaining housing end cap assemblies.
14. Turn on water supply.
15. Turn on power.
16. Perform system startup and flush procedure ([See 2.4. System Startup and Flush Procedure](#)).
17. Inspect system for leaks.



**Figure 18**

!

**MEMBRANES ARE SHIPPED WITH AN ANTI-BACTERIAL PRESERVATIVE. OPERATE THE SYSTEM FOR 1 HOUR TO ASSURE MEMBRANE HAS BEEN COMPLETELY FLUSHED. DO NOT USE WATER PRODUCED DURING THIS RUN-IN PERIOD.**

## 3.7. Monitoring System Performance

Your system will be operating at its peak performance after about 24 hours of operation. You should develop a daily log to track pre-filter pressure, post filter pressure, system pressure, feed water TDS, permeate TDS, permeate flow rate, and waste flow rate. This will allow you to see any developing performance trends or alert you to system changes that will require you to intervene. It will also be helpful for your dealer or Waterite technical personnel to have this information available to help troubleshoot your system, should it be necessary. The table provided in Section 8 will help you get started.

The TDS meter should be recalibrated every 6-12 months using a commercially available calibration solution. Contact your dealer for more information.

## 3.8. Auto Flush Feature

For feed water TDS above 1000ppm, it is strongly recommended that a periodic flush be done to remove sediments and mineral build-ups from the membrane surface. The auto flush program purges high concentrations of dissolved solids out of the system. This helps minimize scale and fouling. To enable auto flush, see [2.2. Controller Programs](#) and [2.3. Switching Between programs](#).



# SECTION 4: SPECIFICATIONS

## System Controller Specifications

### Inputs

Tank level switch	(1) Normally Open. RO runs on switch closure.
Inlet pressure switch	Normally Open. Switch opens on low pressure.
Pre-treat lockout switch *	Normally Open. Pretreat lockout active with switch closure. <b>NOTE: All switch inputs are dry contacts. Voltage applied to the switch inputs will damage the controller</b>
Controller power	120/240 VAC, 60/50Hz (Range: 96-264 VAC) The switching power supply automatically adjusts to supply voltage. Voltage applied to the input is the same voltage the motor and valves will operate on.

### Relay output ratings

Feed solenoid	2A. Output Voltage is the same as motor/supply voltage.
Flush solenoid	2A. Output Voltage is the same as motor/supply voltage. <b>The solenoid relay ratings above reflect the capacity of the relays only.</b> <b>The current capacity of each circuit is 2A.</b>

### Circuit protection

Controller power fuse	F1 5x20mm 1/4(0.25) Amp Little Fuse 0218.250MXP <b>Branch circuit protection, motor and valve protection must be provided externally.</b>
-----------------------	--

\* Pre-treat lockouts are optional equipment (Refer to pre-treatment system valve manual for more information).

## General System Specifications

Model	RSL				RSLHP			
	2400	4800	7200	9600	2400	4800	7200	9600

### Basic System Specifications

Nominal Capacity (GPD)	2400	4800	7200	9600	2400	4800	7200	9600
System Dimensions WxDxH	31"x24"x50"	31"x24"x50"	31"x24"x50"	31"x24"x50"	31"x24"x50"	31"x24"x50"	31"x24"x50"	31"x24"x50"
System Weight (LBS) Dry / Full	96 / 124	114 / 142	132 / 160	154 / 178	96 / 124	114 / 142	132 / 160	154 / 178

### Plumbing Connection Specifications

Inlet Line Size	1" FPT	1" FPT	1" FPT	1" FPT	1" FPT	1" FPT	1" FPT	1" FPT
Reject Line Size	1/2" Push	1/2" Push	1/2" Push	1/2" Push	1/2" Push	1/2" Push	1/2" Push	1/2" Push
	1/2" FPT	1/2" FPT	1/2" FPT	1/2" FPT	1/2" FPT	1/2" FPT	1/2" FPT	1/2" FPT
Product Line Size	3/4" FPT	3/4" FPT	3/4" FPT	3/4" FPT	3/4" FPT	3/4" FPT	3/4" FPT	3/4" FPT
	1/2" Push	1/2" Push	1/2" Push	1/2" Push	1/2" Push	1/2" Push	1/2" Push	1/2" Push
	1/2" FPT	1/2" FPT	1/2" FPT	1/2" FPT	1/2" FPT	1/2" FPT	1/2" FPT	1/2" FPT

### Electrical Requirements

Motor HP	3/4 HP	3/4 HP	1 1/2HP	1 1/2HP	2 HP	2 HP	2 HP	2 HP
Motor Electrical Requirements	230/208V	230/208V	230/208V	230/208V	230/208V	230/208V	230/208V	230/208V
	6.4/7.1A	6.4/7.1A	10.3/11.3A	10.3/11.3A	10.3/11.3A	10.3/11.3A	10.3/11.3A	10.3/11.3A
120V Option (Canada only)	Yes	Yes	No	No	No	No	No	No

### Operational Specifications

Operating Pressure	130 PSI	130 PSI	130 PSI	130 PSI	220 PSI	220 PSI	220 PSI	220 PSI
Maximum Pressure	150 PSI	150 PSI	150 PSI	150 PSI	250 PSI	250 PSI	250 PSI	250 PSI
Minimum Feed Pressure	30 PSI	30 PSI	30 PSI	30 PSI	30 PSI	30 PSI	30 PSI	30 PSI
Feed Pressure Range	30-60 PSI	30-60 PSI	30-60 PSI	30-60 PSI	30-60 PSI	30-60 PSI	30-60 PSI	30-60 PSI
Feed Water Flow Rate	4 USGPM	8 USGPM	12 USGPM	16 USGPM	3.1 USGPM	6.2 USGPM	9.3 USGPM	12.4 USGPM
Feed Flow for Flush	10 USGPM	10 USGPM	10 USGPM	10 USGPM	10 USGPM	10 USGPM	10 USGPM	10 USGPM

### Membrane and Filter Specifications

Number of Membranes	1	2	3	4	1	2	3	4
Membrane Size	4" x 40"	4" x 40"	4" x 40"	4" x 40"	4" x 40"	4" x 40"	4" x 40"	4" x 40"
Pre-Filter Size	5" x 20"	5" x 20"	5" x 20"	5" x 20"	5" x 20"	5" x 20"	5" x 20"	5" x 20"

!

**INSTALLATIONS WITH 208V SERVICE MAY REQUIRE THE USE OF A BOOST TRANSFORMER TO ENSURE A CONSTANT 208V TO THE SOLENOID VALVES. VARIABILITY IN 208V SERVICE CAN CAUSE VOLTAGE TO DROP BELOW THE VALVE REQUIREMENTS.**

## SECTION 5: TROUBLESHOOTING

Problem	Cause	Solution
Low Production	Water supply valve closed	Verify water supply valve position
	Damaged or plugged supply line	Verify supply line condition
	High feed water TDS. Raw water content has changed	Consult dealer. Pre-treatment may be necessary
	Membranes fouled	Replace membrane
	Pre-filter fouled	Replace pre-filter
	Brine seal incorrectly positioned	Re install membrane using lubricant
	Check brine seal for damage	
	Demand exceeding production	Install larger storage tank
Water Leaking	Leaking fitting	Disconnect fitting and re seat tube
	Filter housing leaking	Tighten housing with wrench.
	Inspect O-ring for damage	
	Membrane housing leaking	Tighten clamp
	Pressure relief valve leaking	Replace membranes.
	Inspect lines for blockage	
	Pump leaking	Contact dealer
Low System Pressure	Clogged pre-filter	Replace filter
	Low feed water pressure	Check feed water supply
	Inlet solenoid closed	Verify power supply to unit
	Boost pump malfunctioning	Contact dealer
High System Pressure	Recycle valve out of adjustment	See Step 2.5
	Plugged or restricted recycle valve	Clean or replace
	Crimped or damaged product line	Repair or replace product line
	Membranes fouled	Clean or replace membranes
Permeate TDS Rising	Scaled perforated or fouled membranes	Clean or replace membranes
	Membrane O-rings not sealing	Re-seat or replace O-rings
	Feed water analysis change	Verify feed water analysis and adjust pretreatment.
	Product adaptor O-rings cut or damaged	Verify condition of O-rings, replace as needed
Pre-treatment system not functioning	Verify operation of pre-treatment system such as softener	
Unit keeps turning off	Low pressure cutoff error (Red LED solid or flashing)	Controller will wait 60 seconds and try to restart. Should it fail, the controller will try again in 60 seconds, to a maximum of 5 times in 10 minutes. If the unit has failed to continue to run, then it will go into alarm and will require a power re-set. Verify feed water system.
	Unit running in Manual Mode.	Power button held for 3-5 sec will run unit in Manual mode. Unit will run for 5 minutes then turn off. Turn off / on unit to clear manual mode.
Microbial growth	Contamination of filter or membrane	Wear nitrile gloves when handling filters on membranes. Contact dealer.

# SECTION 6: ELECTRICAL INFORMATION

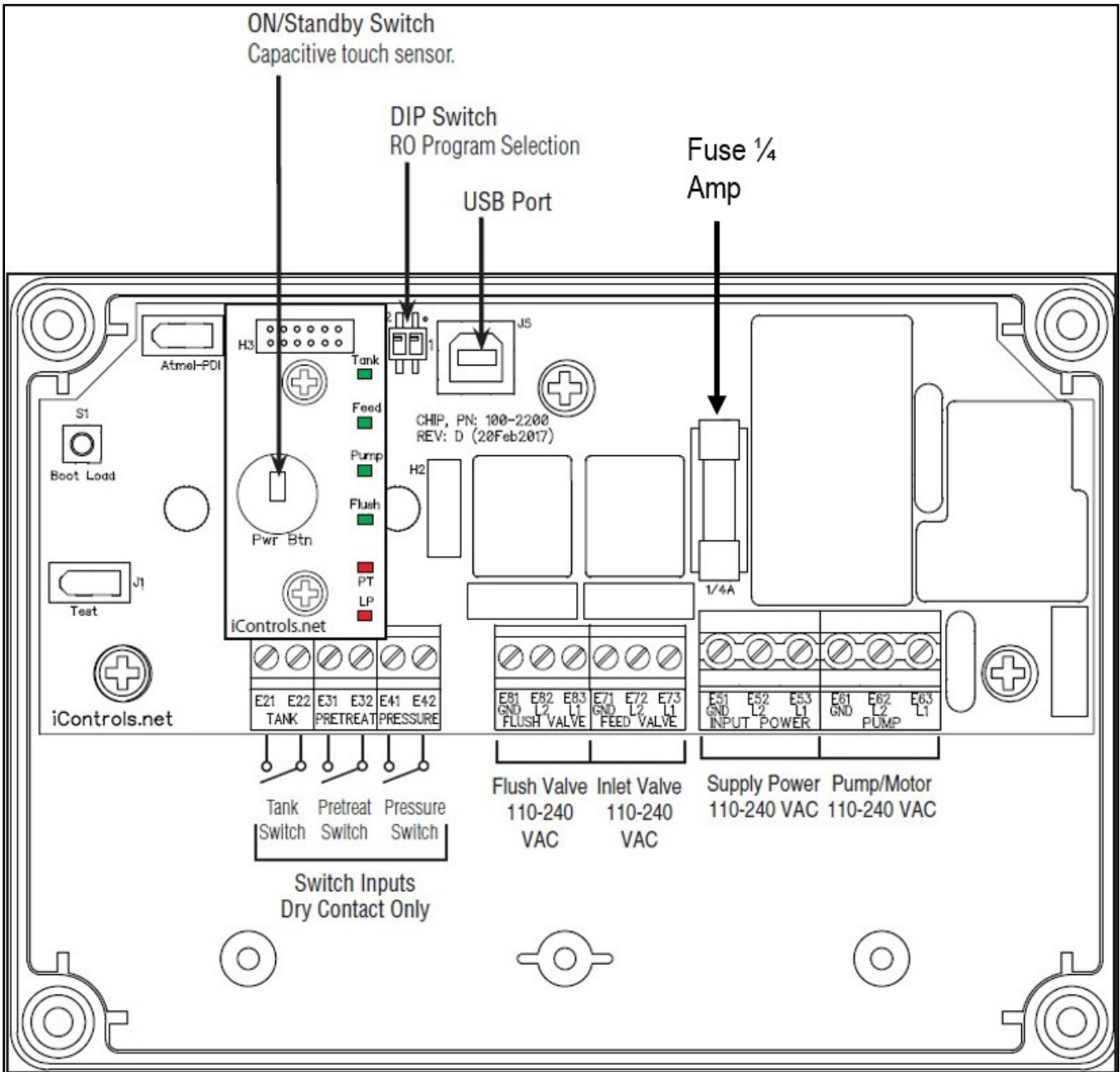

Motor Service factor all units: Amps x 1.30

**ALL RSL AND RSLHP UNITS ARE WIRED 230/208VAC 1 PH 60HZ, UNLESS OTHERWISE SPECIFIED**

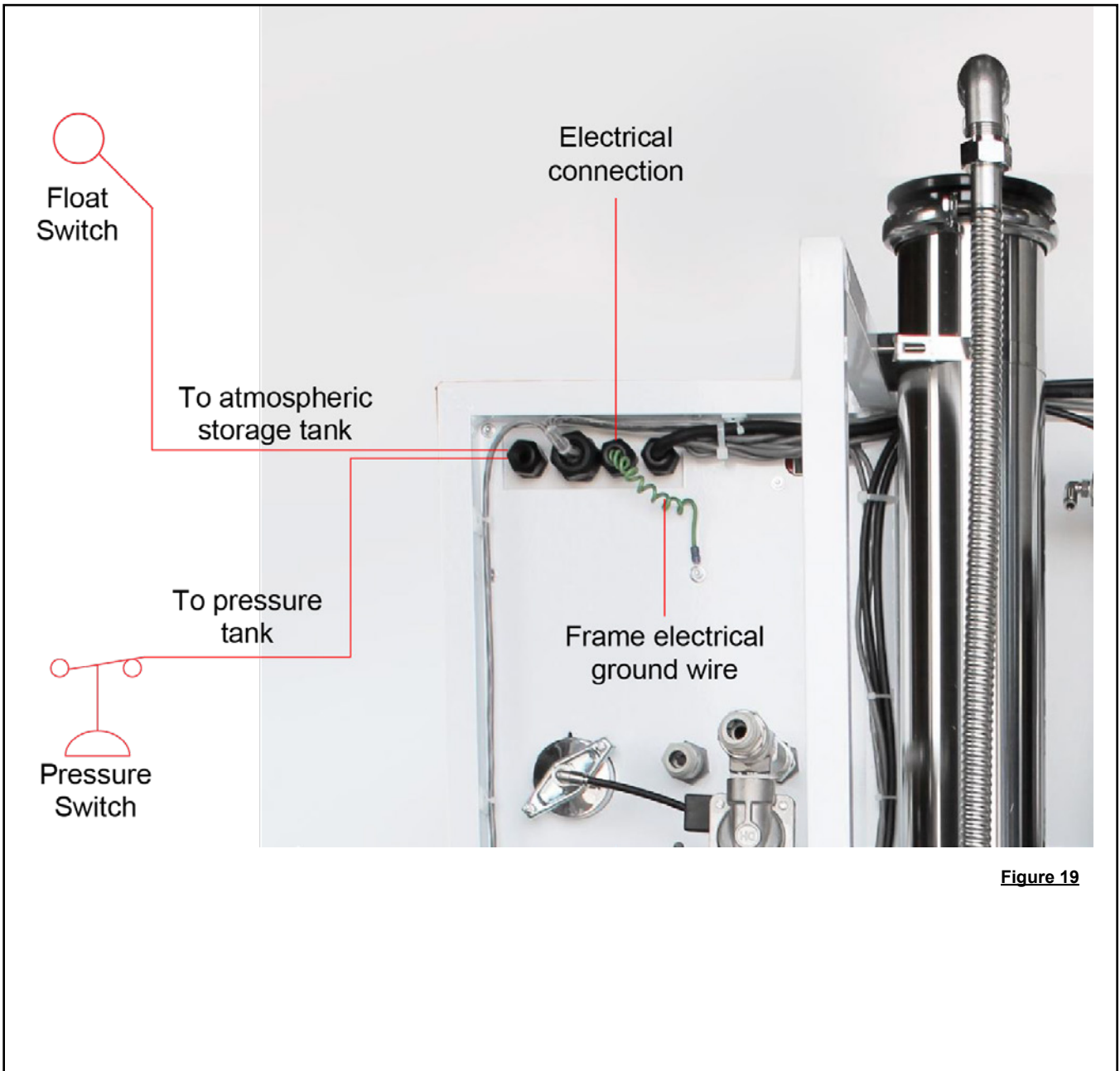

**Figure 19**

# SECTION 7: REPLACEMENT PARTS

	Part Description	Part Number	Models
1	Excelpure 20" 5 Micron PP Spun Cartridge	PP20B05	ALL
2	3/4" Inlet Solenoid	ROSD220	ALL
3	Low Pressure Cut-off Switch N.O.	FRG22	ALL
4	2 1/2" Pressure Gauge, 0-100 psi	LDU10025	ALL
5	2 1/2" Pressure Gauge, 0-200 psi	LDU20025	RSL
6	2 1/2" Pressure Gauge, 0-300 psi	LDU30025	RSLHP
7	Pre-filter Housing Wrench	HAN13W	ALL
8	Product Adapter O-ring	N70210	ALL
9	Membrane Housing End Cap O-ring	N70342	ALL
10	Pre-Filter Housing O-ring	RKE0013HLB	ALL
11	Black Max 4040 Membrane, TFC, XLP	BME4040SXL	RSL
12	Black Max 4040 Membrane, TFC, S	BME4040S	RSLHP

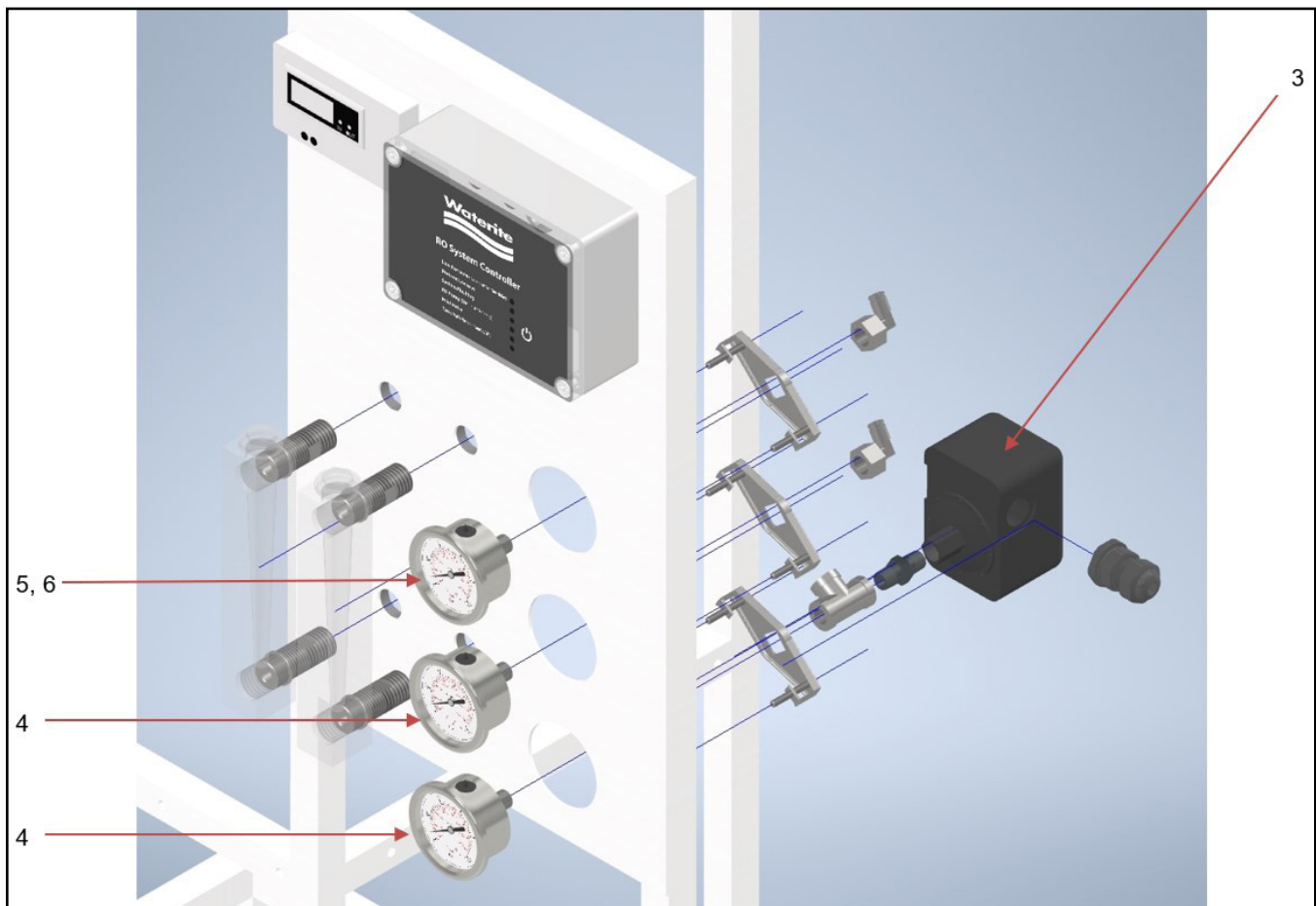



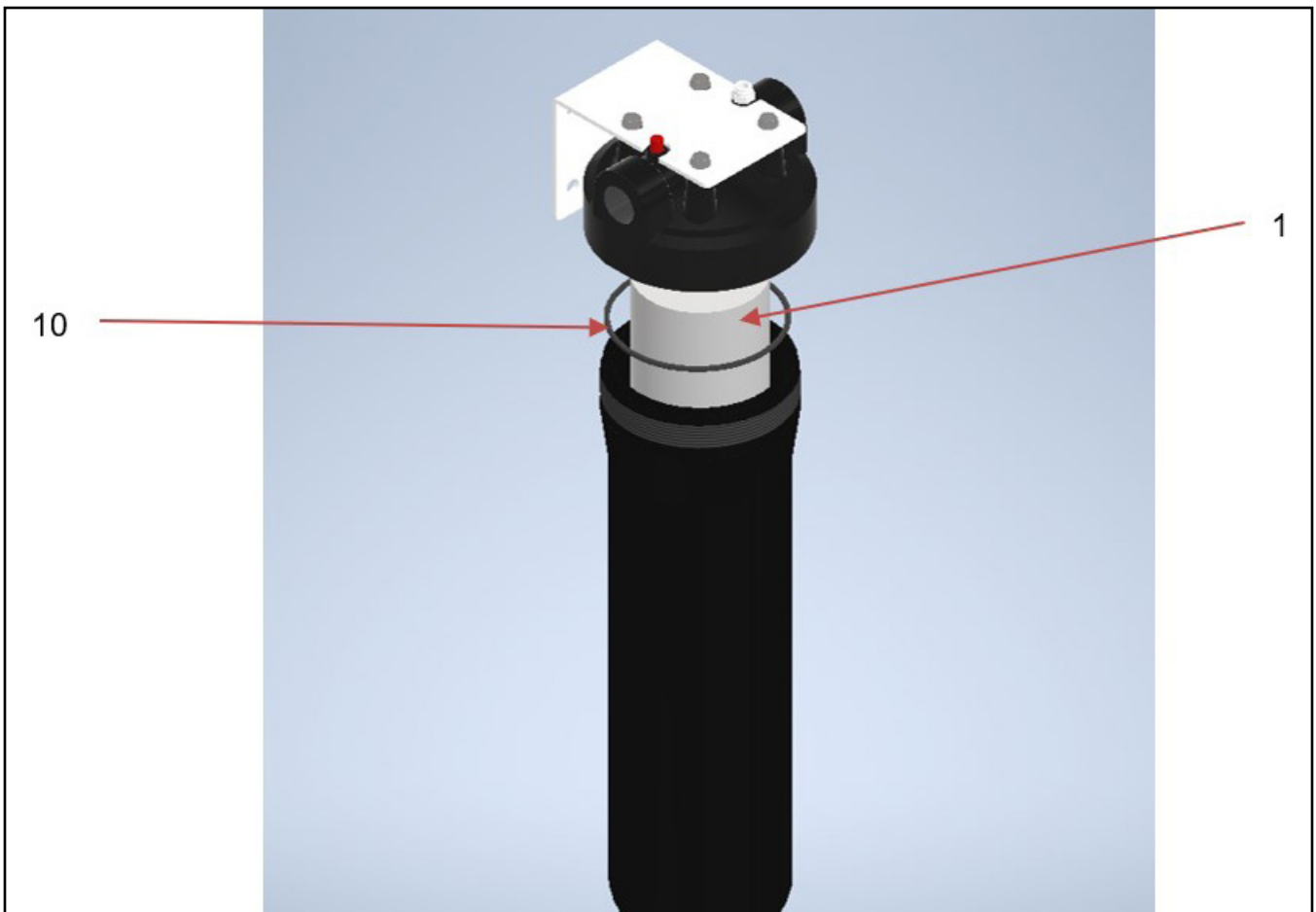
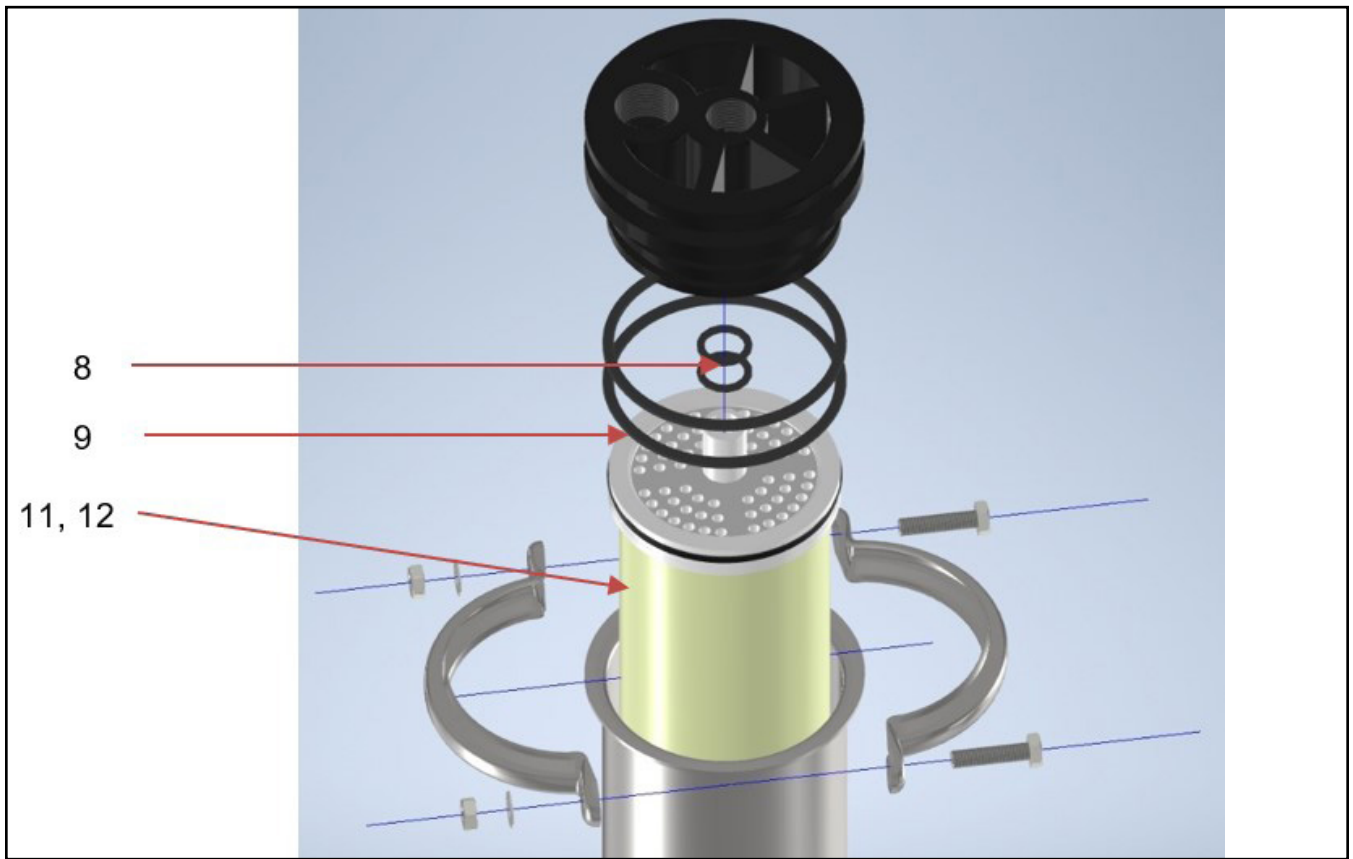



**THIS PAGE HAS BEEN LEFT INTENTIONALLY BLANK**

# **WARRANTY**

## **Vectamaxx RSL and RSLHP Commercial RO Systems**

Every Waterite reverse osmosis system is fully tested after assembly to ensure trouble free operation. This allows us to produce the best product we can. Should an issue arise, keep your bill of sale and your warranty certificate, included in this kit. This is needed to claim any parts or repair service during the warranty period. Read the document completely for warranty claim instructions.

Your VectaMaxx™ RSL system comes with a limited one-year warranty covering materials and workmanship for one year from date of installation, subject to user's compliance with these maintenance and operating instructions. Membranes are excluded from the warranty and the seller's responsibility is limited to any warranty carried by the manufacturer. It is the dealer's responsibility to immediately notify Waterite if defects are detected. Seller shall not be liable for any special, incidental, or consequential damages and will at its option repair or replace any defective components. Warranty excludes O-rings, membranes, pre-filter cartridges, freight charges, removal or installation labor, use with feed water exceeding 2000 PPM TDS for RSL units, or exceeding 4000 PPM TDS for RSLHP units, use of feed water that does not meet recommended conditions and with system alterations made, without a written approval from Waterite.

!

**THIS REVERSE OSMOSIS WATER SYSTEM IS DESIGNED ONLY TO IMPROVE AESTHETIC PROPERTIES AND IS NOT DESIGNED TO ACT AS A PRIMARY BARRIER TO WATERBORNE MICROBIOLOGICAL OR TOXIC CHEMICAL CONTAMINATION. WHERE THESE CONDITIONS EXIST CONSULT A WATER PROFESSIONAL TO ENSURE SUFFICIENT RAW WATER PRE-TREATMENT AND DISINFECTION.**